



Permissions For Reprints Contact: 1-800-640-8285

## How To Hang Lightweight Picture Frame or Mirror

What could be easier than hanging a picture? Hardly anything. But if you want to avoid having to hang the same picture every other week, check out this recipe. This wall mounting technique works with walls made of plasterboard (i.e. dry wall, gypsum, sheetrock walls). Once your picture or mirror is up, only an earthquake will shake it down.

### Utensils

Ruler  
Pencil  
Hammer

### Ingredients

Roll of masking tape  
1 nail, 1/2" or 2" inches long  
White polyvinyl glue

### Approximate Time: 5 To 15 Minutes

1. Establish exact location on the wall where you wish picture or mirror to be hung. Mark the spot lightly with a pencil or fingerprint.
2. Make a cross over the spot with two strips of masking tape (Fig. 38A).
3. Gently hammer nail into center of the cross at an angle of approximately 45 degrees, allowing 1/2" inch protrusion (Fig. 38B).
4. If nail is secure, you may hang the picture or mirror (Fig. 38C).
5. If nail is not secure, remove it and dip it into white glue. Hammer the glued nail into the same hole, still allowing a 1/2" inch protrusion.
6. Let glue dry, then hang picture.

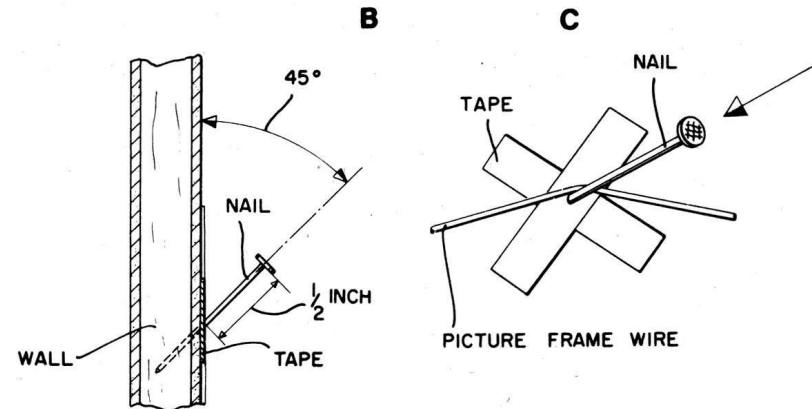
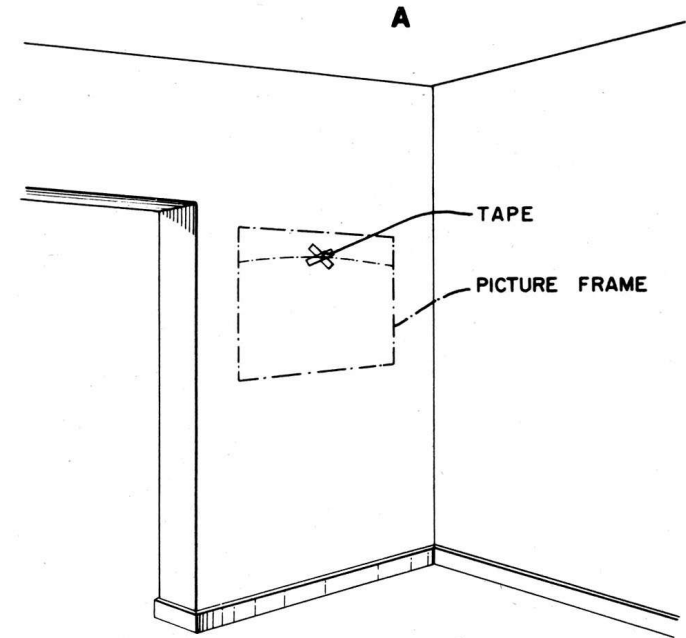

Figure 38.  
One Picture-Hanging Technique